

USER MANUAL

030.03D MC3D COMPACT RED
040.03D MC3D COMPACT GREEN

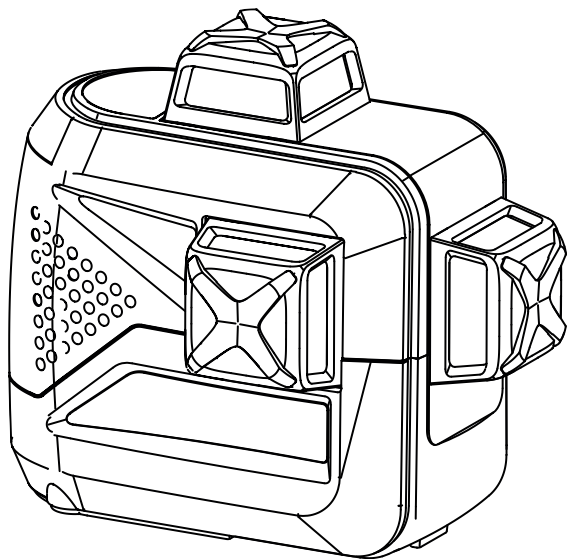

EN ENGLISH

Manual
in your language?

Check the back cover



FUTECH
futech-tools.com

OVERVIEW

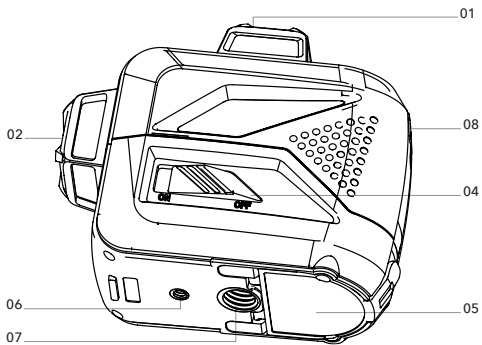
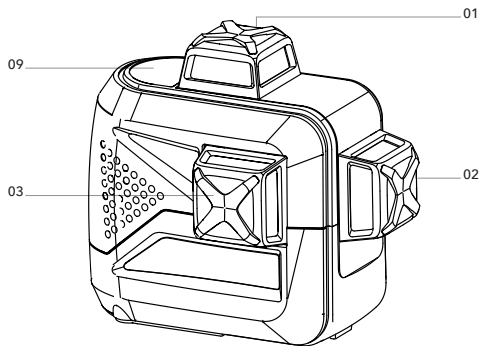

CASE

- 01 Horizontal laserexit
- 02 Vertical laserexit (V1)
- 03 Vertical laserexit (V2)
- 04 Switch On/Off / Transportlock
- 05 Battery compartment
- 06 Tripod thread 1/4"
- 07 Tripod thread 5/8"
- 08 Power socket
- 09 Keypad

KEYPAD

- A Line selection button / Slope button
- B receiver button
- C Slope indicator
- D Receiver indicator
- E Power indicator

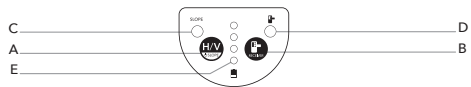

SAFETY

Please read the safety instructions provided as separate booklet with the device.

LASER RADIATION – Class 2 Laser product. – Do not stare into beam

FIRST TIME USAGE

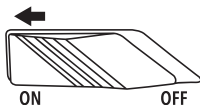

Remove any protective films where applied.

Open the battery compartment **[05]** and insert the li-ion battery. When you use 4x AA alkaline batteries, please take care to respect the indicated polarity.

Shift the transport lock **[04]** to the “ON” position. The laser is switched on, the pendulum levelling mechanism is released, and the instrument is able to align itself on its own.

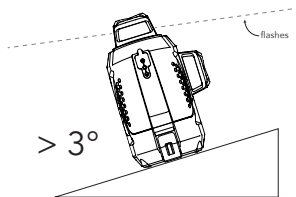

Make sure that the instrument is not on too much of a slope (within 3°). If the slope of the instrument should exceed 3° , the laser lines will flash or will go out automatically.

POWER INDICATOR

The power indicator **[E]** can display four levels of power:

4 LEDS on:	100% battery
3 LEDS on:	75% battery
2 LEDS on:	50% battery
1 LED on:	25% battery

When there is only 1 LED on (25%), battery need to be charged (li-ion) or replaced (4x AA alkaline).

POWER SOCKET / POWER ADAPTOR AND BATTERY SYSTEM

The laser can be powered from main power directly when there is no battery inside the laser or when the li-ion batterie runs flat. Use the included power adapter to provide continuous electricity to laser.

When connecting poweradaptor with the power socket **[08]**, power from li-ion battery will be cut off automatically. In the meanwhile the power adaptor can charge the li-ion battery. When de laser is off and connected with a power adaptor, it charges the li-ion directly. During the charge, the power indicators will be on to indicate how many power has been charged. Without any li-ion battery placed, you can continue to work by connecting the laser with power adaptor.

Alkaline battery pack is also compatible. Simply replacie the li-ion battery by battery pack comes with 4 AA alkaline batteries.

ATTENTION

Never use a power adapter in combination with Alkaline batteries. Loading your device with Alkaline batteries placed may damage your device!

USE

■ HORIZONTAL AND VERTICAL ALIGNMENT

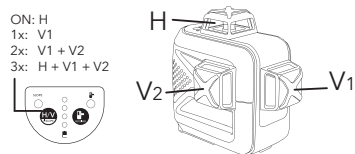

After releasing the transportlock, and provided the instrument is within its levelling range, the horizontal line H **[01]** will light and is automatically levelled. You can activate or deactivate the horizontal and vertical lines using the H/V-button **[A]**.

In order to use vertical lines, press the H/V button **[A]** to activate laser line V1 **[02]**. Press a second time in order to activate laser lines V1 **[02]** and V2 **[03]**. Press another time to activate all laser-lines.

We advise to set the horizontal line on your working height.

ATTENTION

If the workplace is very brightly lit, e.g. out of doors, it may be necessary to use the laser receiver.



■ SLOPE MODE

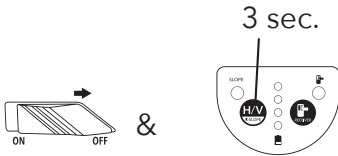

Slide the on/off switch [04] to "OFF" so the laser beams are turned off and the transportation lock is active.

Press 3 seconds on the H/V button [A]. The horizontal laser line H [01] will switch on and the slope indicator [C] will light up. Now sloped lines can be shown by balancing the laser device.

In order to use vertical lines, press the H/V button [A] to activate laser line V1 [02]. Press a second time in order to activate laser lines V1 [02] and V2 [03]. Press another time to activate all laser lines.

Pressing a next time will switch off the laser.

IMPORTANT

In slope mode, the laser lines no longer levelled automatically. A slow flashing laser lines will remind you that the laser is not in automatic leveling mode.

■ RECEIVER MODE

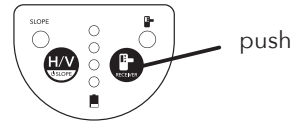



Press the receiver button [B] to turn on the receiver mode (pulse). When this mode is activated, the receiver indicator [D] will light up. At this moment, laserlines can be picked up by a laser receiver.

Press the receiver button [B] again to turn off the receiver mode (pulse).

NOTE

All Futech laser will use 10Khz as frequency in receiver mode. Only receivers that can detect laser lines at 10Khz are compatible.

TECHNICAL SPECIFICATIONS

	030.03D MC3D COMPACT RED	040.03D MC3D COMPACT GREEN
Visibility		
Accuracy	± 3mm / 10m	
Range with receiver	2x 50m	
Levelling range	± 3°	
Levelling	pendulum levelling	
Slope function	manual (via pendulum lock)	
Tripod thread	1/4" and 5/8"	
Laser wavelength	638nm	515nm
Laser classification	Class II	
Power supply	LI-ION accu or 4x Alkaline AA	
Protection	IP54	
Dimensions (l x w x h)	148 x 87 x 129 mm	
Weight	0,740 kg	
Operation temperature	-10°C ~ +50°C	





DECLARATION OF CONFORMITY

Futech (Belgium) declares under its own responsibility that this device:

- 030.03D, MULTICROSS 3D COMPACT RED
- 040.03D, MULTICROSS 3D COMPACT GREEN

is in conformity with the standards

EN 61000-6-3:2007+A1:2012,
EN 61000-6-1:2008,
EN 61010-1:2011,
EN 60825-1:2015,

following the provisions of Directive(s)

2014/30/EU
2014/35/EU.

Lier, Belgium,
June 15, 2017
Patrick Waüters

NOTES

Potential misprints are reserved. Images used are not strict. All features, functionality and other product specifications are subject to change without notice or obligation.

USER MANUAL

other languages:



DA DANSK



DE DEUTSCH



ES ESPAÑOL



ET EESTI KEEL



FI SUOMEN KIELI



FR FRANÇAIS



IS ÍSLENSKA



IT ITALIANO



NL NEDERLANDS



NO NORSK



PT PORTUGUÊS



SL SLOVENŠČINA



SV SVENSKA



Facebook
@futechtools



LinkedIn
futechtools



World Wide Web
futech-tools.com



YouTube
@futechtools